

## ERGONOMIC LIFTING FLEXIBILITY AT THE LIBRARY

Our Protema range of electric trolleys offer a variety of models with a choice of lifting height, lifting capacity and applications.

Our construction department adapts the standard range continuously to keep up to date with customer specifications. The lifters are type-certified by third party in accordance with the CE/Machine directive.

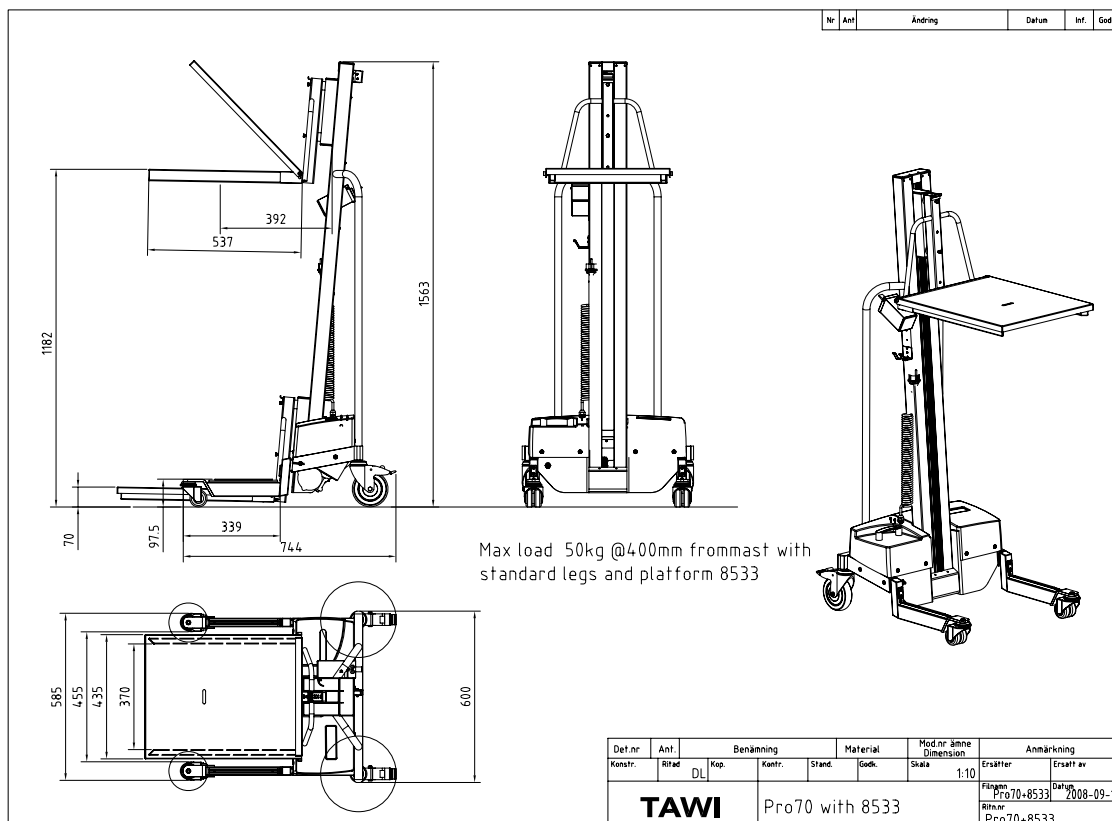

## ELECTRIC TROLLEY - LIBRARY VERSION

- Tool for returnable plastic crates. Built in aluminium and stainless steel for easy handling and low-maintenance lifting aid.

- Platforms/accessories:

Foldable platform with forks underneath, adapted to suit a specific plastic crate dimension.

- User friendly:

Maintenance-free battery, built-in charger that plugs into wall outlet over night.

- Safe:

Overload protection. CE-certified and manufactured in accordance with the Machine Directive.

Available in other sizes for increased lifting height and with several accessories, such as ladder to reach even higher. Contact TAWI for more info!

|                           |  |
|---------------------------|--|
| Model                     | PRO70-LIBRARY  |
| Capacity                  | 50 kg with centre of load @ 400 mm from mast with platform art nr 8533 |
| Min lifting height        | Golvnivå (70 mm)   |
| Max lifting height        | 1182 mm  |
| Stroke                    | 1112 mm  |
| Weight                    | 30 kg  |
| Lifting speed             | 0.08 m/s with 50 kg load   |
| Charging voltage          | 240 V/AC, 55 W   |
| Battery voltage           | 12 V/DC  |
| Battery capacity          | 17 Ah  |
| Lifting capacity / charge | 50 kg 1 m x 100  |



TAWI AB

Box 10205 434 23 KUNGSBACKA SWEDEN

Tel +46 300 18500

info@tawi.se www.TAWI.com